

Chronic hypercalcaemia from inactivating mutations of vitamin D 24-hydroxylase (CYP24A1): implications for mineral metabolism changes in chronic renal failure

Giacomo Colussi¹, Liat Ganon², Silvana Penco³, Maria Elisabetta De Ferrari¹, Federica Ravera¹, Marialuisa Querques¹, Paola Primignani³, Eli J. Holtzman² and Dganit Dinour²

¹Division of Nephrology, Dialysis and Renal Transplantation, A.O. Ospedale Niguarda-Ca' Granda, Milan, Italy, ²Department of Nephrology and Hypertension, the Chaim Sheba Medical Center, Tel-Hashomer and the Sackler School of Medicine, Tel-Aviv University, Tel-Aviv, Israel and ³Medical Genetics Unit, Laboratory Medicine, A.O. Ospedale Niguarda-Ca' Granda, Milan, Italy

Correspondence and offprint requests to: Giacomo Colussi; E-mail: giacomo.colussi@ospedaleniguarda.it

ABSTRACT

Background. Loss-of-function mutations of vitamin D-24 hydroxylase have recently been recognized as a cause of hypercalcaemia and nephrocalcinosis/nephrolithiasis in infants and adults. True prevalence and natural history of this condition are still to be defined.

Methods. We describe two adult patients with homozygous mutations and six related heterozygous carriers. Mineral and hormonal data in these patients were compared with that in 27 patients with stage 2–3 chronic kidney disease and 39 healthy adult kidney donors.

Results. Probands had recurrent nephrolithiasis, chronic hypercalcaemia with depressed parathyroid hormone (PTH) and increased 1,25(OH)₂D levels; carriers had nephrolithiasis (two of six), hypercalciuria (two of six) and high or normal-high 1,25(OH)₂D (four of four). Corticosteroids did not reduce plasma and urine calcium levels, but ketoconazole did, indicating that 1,25(OH)₂D production is not maximally depressed despite co-existing hypercalcaemia, high 1,25(OH)₂D and depressed PTH, and that 1,25(OH)₂D degradation through vitamin D-24 hydroxylase is a regulator of plasma 1,25(OH)₂D levels. Both probands had vascular calcifications and high bone mineral content. One developed stage 3b renal failure: in this patient 1,25(OH)₂D decreased within normal limits as glomerular filtration rate (GFR) fell and PTH rose to high-normal values, yet hypercalcaemia persisted and the ratio of 1,25(OH)₂D to GFR remained higher than normal for any degree of GFR.

Conclusions. This natural model indicates that vitamin D-24 hydroxylase is a key physiologic regulator of calcitriol and plasma calcium levels, and that balanced reduction of 1,25

(OH)₂D and GFR is instrumental for the maintenance of physiologic calcium levels and balance in chronic kidney diseases.

Keywords: CYP24A1, hypercalcaemia, hypercalciuria, nephrocalcinosis, nephrolithiasis, vitamin D-24 hydroxylase

INTRODUCTION

Hypercalcaemia is dangerous for human health: it is a cause of recurrent renal stones/nephrocalcinosis, acute as well as chronic renal failure, peptic ulcer disease and pancreatitis, different degrees of bone demineralisation and fragility according to cause [1–3], arterial vasoconstriction and hypertension [4] and possibly arterial calcifications [1, 2, 5]. Even in a supposedly benign condition, such as 'asymptomatic' primary hyperparathyroidism, it may reduce life expectancy [6, 7]. So one may assume that the control of plasma calcium levels within current physiologic ranges in humans resulted from evolutionary survival advantage over higher or lower levels.

In clinical practice, a thorough search for specific cause is mandatory in every case of chronic hypercalcaemia. We present two patients with a 'difficult to diagnose' cause of chronic hypercalcaemia, who eventually proved to bear loss of function, homozygous mutations of vitamin D-24-hydroxylase enzyme [24(OH)ase], encoded by CYP24A1. One of the patients has a 30-year-long history of clinical observation before correct diagnosis was made; he developed progressive renal failure during this time, but hypercalcaemia did not abate, despite the fall of 1,25-dihydroxy-vitamin D [1,25(OH)₂D] levels within

physiologic ranges, and the rise of parathyroid hormone (PTH) from suppressed values to inappropriately normal levels in the presence of hypercalcaemia. Investigation of hypercalcaemia mechanisms throughout different degrees of renal function and $1,25(\text{OH})_2\text{D}$ levels highlights the role of balanced changes of $1,25(\text{OH})_2\text{D}$ and renal function in the control of calcium balance and levels in chronic renal failure.

MATERIALS AND METHODS

Patients

We report and analyse clinical, biochemical and imaging data concerning two still unreported adult patients, with recurrent calcium nephrolithiasis, hypercalcaemia, suppressed PTH, elevated plasma $1,25(\text{OH})_2\text{D}$ levels and renal failure in one, who eventually were proven to have homozygous mutation in CYP24A1. A total of six family members of the patients were also available for clinical, genetic and biochemical evaluation. Data were mostly collected retrospectively from clinical charts and hospital databases; all investigations were diagnosis- and therapy-oriented, and covered for Patient 1 more than 22 years. Patients and family members gave written consent to genetic testing and to anonymous data reporting.

Mutation screening and genotyping

Genomic DNA was extracted from peripheral blood leucocytes using standard methods. The whole coding sequence of CYP24A1 gene including splice sites was sequenced as published [8].

Biochemical parameters and comparison data

Biochemical data were obtained with routine methods in our laboratory. Reference values are from published normal controls [9] for the more ancient data in Patient 1, and from 39 adult kidney donors ('healthy controls') evaluated at our institution in the last 5 years. To account for declining renal function in Patient 1 over time, 27 random patients with stage 2–3 [calculated 24-h creatinine clearance (CCr) 27–75 mL/min], slowly progressing, chronic kidney disease followed up at our institution (CKD controls) were also evaluated. In the last 5 years, PTH was measured by electro-chemiluminescence immuno assay using the PTH STAT Kit, Roche Diagnostics GmbH, Mannheim, Germany and $1,25(\text{OH})_2\text{D}$ by radio-immunoassay using the Immunodiagnostic Systems kit (IDS, Ltd, Boldon, UK). FGF23 was measured with three commercially available ELISA kits: from Immunotopics, San Clemente, CA (c-terminal and intact), and Kainos, Tokyo, Japan (intact); reference values for all three methods were taken from a published paper in patients with tumour-induced osteomalacia [10].

Statistics

Data are presented as median and ranges; comparison between groups was performed by use of the Mann–Whitney test for nonparametric data. Correlation analysis was performed by use of least squares method and Pearson's correlation coefficient for defining the significance of associations between data. Linear regression analysis by use of the least

squares was also performed for every significant correlation; linear as well as exponential or power regressions were checked by log transformation of independent or dependent variables, as indicated, and the best fit was shown in figures. A two-tailed P value of ≤ 0.05 was taken as statistically significant.

RESULTS

Genetic analysis

Both patients had homozygous mutations of CYP24A1: Patient 1 had an already described [8, 11–13] in-frame deletion of a highly conserved glutamate at position 143 (delE143, exon 2), and Patient 2 had a missense already published [11, 14] substitution of arginine at position 396 to tryptophan (R396W, exon 9). Both mutations induce almost complete loss of enzyme function *in vitro* [11, 13]. There was no consanguinity, but parents of both patients came from the same Italian region or town. Brother and daughter of Patient 1 were found to be heterozygous for delE143. Parents and two children of Patient 2 were found to be heterozygous for R396W. Fathers of both Patient 1 (not genotyped) and 2 (heterozygous carrier) were affected by nephrolithiasis (Figure 1).

Patient history and data

Patient 1 was a 49-year-old male referred to us in 1991; he had been suffering from bilateral renal calcium-oxalate stones since his 20s, and, at 27 years, he underwent left nephrectomy due to ureteral obstruction and infection. Subsequently, several surgical and lithotripsy procedures had to be repeated on the right kidney for recurrent calcium stones. Hypercalcaemia had been known since 1980; when evaluated at our institution, he had mild to moderate hypercalcaemia, normal to slightly reduced serum phosphate levels, suppressed PTH, high-normal to definitely increased plasma $25(\text{OH})_2\text{D}$ and $1,25(\text{OH})_2\text{D}$ levels and stage 2 renal insufficiency (Table 1). Blood ACE, plasma and urine immunoelectrophoresis, chest X-ray, bone marrow histology were all normal. Due to increased $25(\text{OH})_2\text{D}$ levels, exogenous vitamin D intake was suspected, but never substantiated; oral glucocorticosteroid (CS)

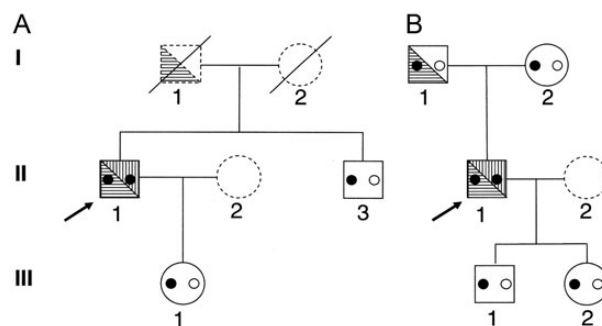

FIGURE 1: Family pedigree in Patients 1 (A) and 2 (B). Index cases are indicated by arrows. Hatched circles and squares indicated ungenotyped subjects. Black and open circles within-subjects' symbols indicate mutated and wild-type allele, respectively. Horizontal-line area within-subjects' symbols indicate nephrolithiasis vertical-line area hypercalcaemia.

Table 1. Main biochemical data in the two patients and six heterozygous carriers

	Genotype		P _{Ca} (mg/dL)	P _{Ph} (mg/dL)	U _{Ca} /U _{Cr} (mg/mg)	T _{mp} (mg/dL/GFR)	PTH (pg/mL)	25(OH)D (ng/mL)	1,25(OH) ₂ D (pg/mL)	CCr (mL/min)
	Allele 1	Allele 2								
Patient 1	delE143	delE143	11.63	3.2	0.17	2.2	8.4	56.3	56.7	67.5
n.v.*			10.7–12.6 (18)	2.8–3.8 (18)	0.1–0.25 (10)	1.8–3.2 (17)	0.6–12.5 (13)	32–134 (15)	37–81 (14)	62–82 (17)
Patient 2	R396W	R396W	8.6–10.2	2.7–4.7	0.05–0.17	2.4–4.4	18–66	5–45	15–55	76–140
n.v.**			10.1	2.6	0.27	2.0	11	36	98	91.5
Family 1			10–10.2 (3)	2.5–2.7 (2)	0.22–0.33 (3)	–(1)	10–13 (3)	32–41 (2)	63–133 (3)	90–93 (3)
II 3	delE143	w.t.	8.6–10.2	2.7–4.7	0.05–0.17	2.4–4.0	20–75	5–45	20–82	60–157
III 1	delE143	w.t.	9.2	3.1	0.11	2.7	55	31	50	169
Family 2			9.4	2.9	0.12	2.7	23	23	116	160
I 1	R396W	w.t.	9.2	2.6	0.12	–	46	19	94	85
I 2	R396W	w.t.	9.4	3.1	0.18	2.5	28	18	73	60
III 1	R396W	w.t.	–	–	0.24	–	–	–	–	–
III 2	R393W	w.t.	–	–	0.06	–	–	–	–	–

Values are median, ranges and (number of observations). For Patient 1, onset data (years 1991–2000) are shown, and compared with historical (*) controls. Family members are indicated by generation level according to Figure 1. n.v.: 95% distribution ranges (± 1.96 SD of mean) in: *16 control subjects in years 1990–2000 (ref. [9]) and **39 adult kidney donors in years 2009–13. w.t. denotes wild-type allele.

test (0.5 mg/kg prednisone for 2 weeks) did not reduce plasma calcium and slightly increased calciuria. The challenge was repeated thrice, for longer periods and the last time with methylprednisolone 40 mg i.v./day, with the same results (Figure 2). Ketoconazole 600 mg p.o./day for 1 month and later for 6 months incompletely reversed the biochemical profile: urine calcium excretion normalized and plasma calcium fell without normalization, PTH rose to normal ranges and 1,25(OH)₂D levels fell during treatment but rose again out of treatment (Figure 2). The full biochemical profile recurred when the drug was stopped for patient intolerance. The patient was treated with low-calcium diet, potassium citrate and high fluid intake. In 2005, he was diagnosed with demyelinating neuropathy, and long-term steroid therapy was prescribed, again without any changes in plasma calcium levels. Beginning from 2003 to 04, despite no new stones or urologic events, renal function slowly decreased from stage 2 to stage 3b, without apparent causes outside hypercalcaemia itself and reduced renal mass. In parallel with declining renal function, biochemical profile showed definite changes: urine calcium excretion progressively fell, together with fall in 1,25(OH)₂D and rise in PTH levels within normal levels (Figure 3), yet plasma calcium levels remained definitely increased (Tables 1 and 2). Recently, FGF23 levels were found increased with c-terminal Immunotopics and intact Kainos assay (Table 2). BMD by DEXA, performed in 2010 and 2013, was increased at 1.371 and 1.323 g/cm², respectively (Z score 3.4 and 3.0, T score 2.5 and 2.1) in lumbar spine and normal at 0.836 and 0.916 (Z score 0.4 and 1.0, T score –0.7 and –0.1) in the femoral neck. In 2011, a lumbar CT, performed for neurological indication, showed severe, circumferential calcification of the whole abdominal aorta down to the iliac arteries. In 2012, he had myocardial ischaemia, and a coronary angiography showed severe diffuse coronary artery calcifications and stenosis. Traditional risk factors for artery disease in the patient include mild hypertension since 1997, treated with angiotensin II blocker, moderate hypercholesterolaemia, treated with statins in the last 10 years, but not smoking, diabetes, overweight.

Both his parents died (the father had several renal stone episodes), a brother and a daughter are normocalcemic and normocalciuric, but the daughter (III1) has definite increase of 1,25(OH)₂D plasma levels (Table 1).

Patient 2 is a 47-year-old male recently referred to us because of recurrent bilateral calcium nephrolithiasis and intermittent hypercalcaemia. He has been suffering from renal stones (calcium oxalate with trace phosphate) since he was 18 years old. On March 2012, he had stone-induced obstruction of the right ureter, requiring endoscopic lithotripsy. Biochemical data show high ionized calcium (1.41 mmol/l, n. v. < 1.35) with total calcium levels at the upper limits of normal, hypophosphataemia, definite hypercalciuria, depressed PTH and high 1,25(OH)₂D with normal 25(OH)D levels and normal renal function (Table 1). Plasma ACE, serum protein electrophoresis, blood counts and chest X-ray are normal. A corticosteroid challenge (prednisone 0.5 mg/kg/day for 2 weeks) did not change plasma or urine calcium and PTH (Figure 2). FGF23 levels are increased only with the Kainos intact assay (Table 2). An abdomen CT, performed for

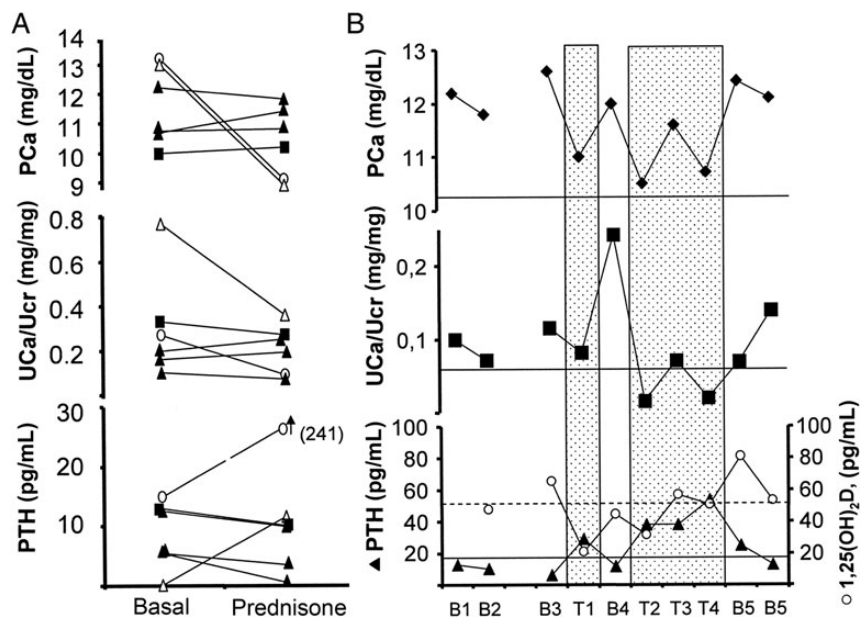

FIGURE 2: (A) Results of corticosteroid administration in Patients 1 (full triangles) and 2 (full square). In Patient 1, the test was performed thrice. For comparison, results in two hypercalcaemic patients with sarcoidosis (open symbols) are shown. (B) Results of ketoconazole administration (600 mg/day) in Patient 1. The scale in abscissa is conventional: shadowed areas denote treatment. B(n) are data out of treatment, T(n) are data points on treatment, which lasted 3 months (first shadowed area) and 6 months (second shadowed area), respectively. Solid horizontal lines denote upper (plasma and urine calcium) and lower (PTH) normal limits; interrupted line upper normal calcitriol level. Urine calcium reference is for patients with stage 3 renal failure.

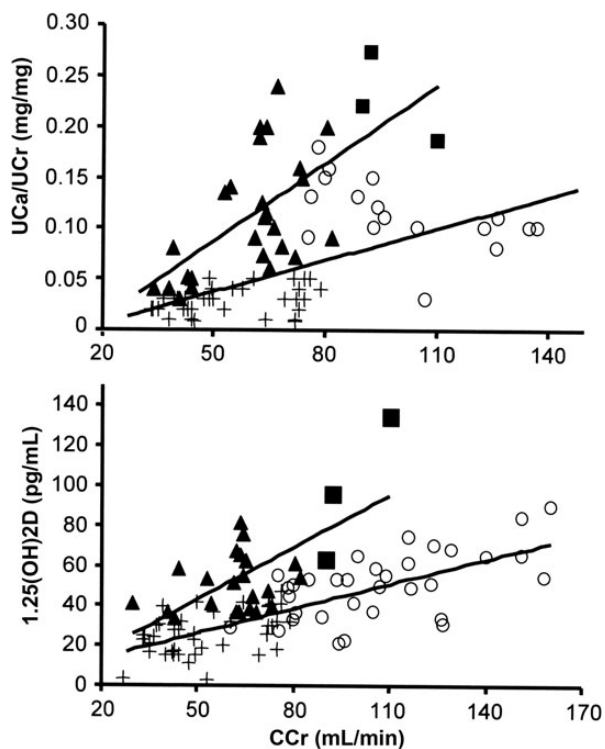

FIGURE 3: Relationship between creatinine clearance (CCr) and daily urine calcium to creatinine ratio (upper figure) and 1,25(OH)₂D (lower figure). Linear regression line is shown for patients (full triangles: Patient 1; full squares: Patient 2) and pooled healthy (open circles) and CKD controls (crosses).

study of ureteral stone, shows scattered calcifications along abdominal aorta and iliac artery walls. Traditional risk factors for artery disease include mild hypertension (under optimal pharmacological control) but not smoking, diabetes, hyperlipidaemia or overweight. A DEXA BMD is at the upper normal both in spine (1.395 g/cm², Z-score 1.7 and T-score 1.5) and femoral neck (1.165, Z-score 1.4, T-score 0.7).

Both parents are heterozygous carriers of the same mutation and are normocalcaemic; however, in both 1,25(OH)₂D is normal-high, the mother has mild hypercalciuria and the father has history of calcium renal stones; both children are heterozygous carriers and healthy; only urine 'spot' data were evaluated, showing hypercalciuria in the 9-year-old boy (III1, Table 1).

Analysis of biochemical parameters in patients compared with controls

Patient 1's CCr decreased over time to about half the levels at presentation. Despite persistent hypercalcaemia, the patient has shown in recent years progressive increase of PTH (range 28–93 pg/mL), decrease of 1,25(OH)₂D within normal levels (36.9–42.5 pg/mL), and reduction of urine calcium excretion (0.03–0.08 mg/mg Cr) (see also Table 2). This prompted us to analyse the relationship, if any, between changes in glomerular filtration rate (GFR) and vitamin D metabolic profile. All data available since 1991 (excluding those on specific treatments, such as ketoconazole) in both patients were correlated and

Table 2. FGF23 values and related biochemical data in the two patients

	P _{Ca} (mg/dL)	P _{Ph} (mg/dL)	U _{Ca} /U _{Cr} (mg/mg)	TmP (mg/dL GFR)	PTH (pg/mL)	25(OH)D (ng/mL)	1,25(OH)D (pg/mL)	CCr (mL/min)	FGF23ci (RU/mL)	FGF23ii (pg/mL)	FGF23ik (pg/mL)
Patient 1	11.5	3.1	0.03	2.18	46	14.6	36.9	41.5	277.7	28.6	255.7
Patient 2	10.1	2.71	0.22	1.99	10	32.4	134.5	110.1	79.8	9.2	76.0
n.v.	8.6–10.2	2.7–4.7	0.04–0.18 ^a	2.4–4.0	20–75	5–45	20–82	–	72.9 ± 38.2 ^b	13.3 ± 19.0 ^b	29.7 ± 20.7 ^b

Suffix for FGF23: ci, c-terminal Immunotopics; ii, intact Immunotopics; ik, intact Kainos.

^aReference range for Patient 1 (stage 3 CKD): 0.01–0.05.

^bData are from reference [10]: higher cut-off is 149 (ci), 51 (ii) and 71 (ik).

compared with healthy subjects (i.e. 39 kidney donors) and 27 patients with CKD.

In the patients, CCr was directly correlated with both daily urine calcium excretion (expressed as urine Ca to creatinine ratio, UCa/UCr) ($r = 0.78$, $P < 0.01$) and 1,25(OH)₂D levels ($r = 0.69$, $P < 0.01$); patients had higher UCa/UCr and 1,25(OH)₂D than in healthy and CKD controls for any CCr value (Figure 3). Healthy and CKD controls were pooled together to span the whole range of CCr as in the patients: correlation coefficients were 0.64 ($P < 0.01$) for UCa/UCr and 0.78 ($P < 0.01$) for 1,25(OH)₂D versus CCr.

Higher 1,25(OH)₂D levels for any degree GFR were numerically expressed by a significantly higher ratio of 1,25(OH)₂D to CCr (a theoretical standardization of plasma 1,25(OH)₂D levels to unit GFR/renal mass) in the patients [87.7 (59–122) pg/dLCCr] versus controls [healthy controls 46.6 (22–73); CKD 52.2 (13–76); pooled healthy and CKD controls 50.1 (13–76), $P < 0.001$ for all].

Calcium excretion (as UCa/UCr) was also positively correlated with 1,25(OH)₂D in the patients ($r = 0.36$, $P < 0.05$) and in pooled healthy and CKD controls ($r = 0.36$, $P < 0.05$) (data not shown). 1,25(OH)₂D was not correlated with 25(OH)D both in patients ($r = 0.016$, $P > 0.1$) and healthy controls ($r = -0.19$, $P > 0.1$) or CKD ($r = -0.06$, $P > 0.1$) (data not shown).

Concerning PTH, it was inversely correlated to CCr ($r = -0.73$, $P < 0.01$) in the patients, and in pooled healthy and CKD controls ($r = -0.48$, $P < 0.01$) (Figure 4, where the best fit is shown as exponential in patients, $r = -0.82$, and power in controls, $r = -0.53$). For any level of CCr, PTH was definitely lower in the patients. PTH was also inversely correlated to 1,25(OH)₂D both in the patients ($r = -0.45$, $P < 0.01$) and in pooled healthy and CKD controls ($r = -0.31$, $P < 0.01$) (Figure 4 where the best fit is exponential for both patients, $r = -0.51$ and controls, $r = -0.38$). Although the patients had lower PTH levels at the upper 1,25(OH)₂D levels, there was a substantial overlapping of values in the low-normal 1,25(OH)₂D range (Figure 4).

PTH was not correlated to plasma calcium values in the patients ($r = 0.04$, $P > 0.1$) but was slightly correlated in pooled healthy and CKD controls ($r = -0.27$, $P < 0.05$) (Figure 4).

There was a direct correlation between plasma calcium and 1,25(OH)₂D in pooled healthy and CKD controls ($r = 0.45$, $P < 0.01$) but not in the patients ($r = -0.07$, $P > 0.1$) (data not shown); moreover, a direct correlation was found between plasma calcium and the ratio of 1,25(OH)₂D to CCr in the whole set of data in patients and controls ($r = 0.55$, $P < 0.01$; Figure 5).

DISCUSSION

We describe two additional patients with the newly described entity of loss of function mutation of the enzyme 24(OH)ase, the mitochondrial cytochrome P-450 transcript of the gene CYP24A1. First recognized in children with so-called idiopathic infantile hypercalcaemia [11, 12], it is increasingly being detected in adult patients [8, 13, 15–17] who all share with our patients the features of recurrent nephrolithiasis/

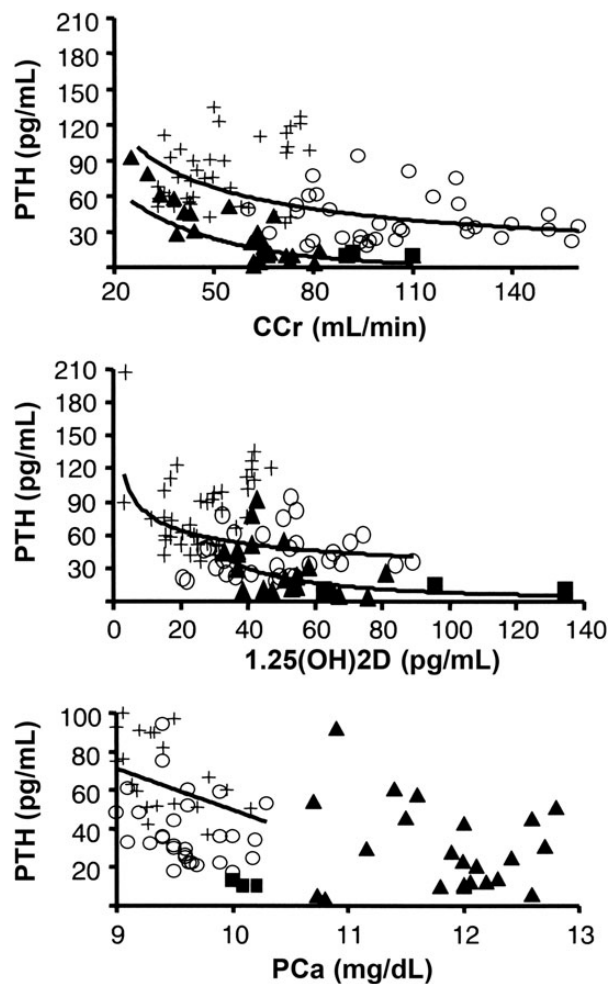

FIGURE 4: Relationships between PTH (ordinate) and creatinine clearance (CCr, upper), calcitriol (middle) and plasma calcium (PCa, lower). Symbols as in Figure 3. The best fit is shown for significant correlations in patients (exponential regressions) and pooled healthy and CKD controls (power regression upper and exponential middle figures, linear regression lower figure).

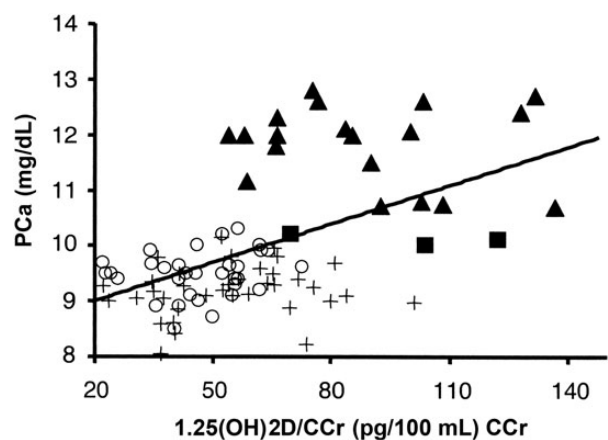

FIGURE 5: Relationship between plasma calcium (PCa) and the calcitriol to CCr ratio (abscissa). Symbols as in Figure 3. Linear regression line is shown for the whole set of data.

nephrocalcinosis and calcitriol-dependent hypercalcaemia/urea with suppressed PTH levels.

Basic mechanism of this disorder is calcitriol excess secondary to lack of inactivation by 24(OH)ase. CYP24A1 catalyses multiple hydroxylation reactions, beginning at carbons C-24 or C-23 of the side chain of both 25(OH)D and 1,25(OH)₂D (either vitamin D₂ or D₃) as well as of synthetic VDR agonists [e.g. paricalcitol, doxercaliferol and 22-oxa-1,25(OH)₂D], ending in the formation of water-soluble inactive compounds [18, 19]. This enzyme has emerged as a key regulator of calcitriol circulating and tissue levels and biologic effects: it is expressed in every cell/tissue expressing the vitamin D receptor (VDR), and undergoes tight regulation by the main regulators of vitamin D-1 α -hydroxylase (CYP27B1), namely PTH, FGF23 and vitamin D receptor agonists [i.e. 1,25(OH)₂D itself], though in opposing directions [19, 20]. Thus, VDR activation by 1,25(OH)₂D induces, among other effects, inactivation of the agonist itself and dissipation of its effects through CYP24A1 induction [18, 19]. In CYP24A1-null mouse plasma and tissue, clearance of both 25(OH)D and 1,25(OH)₂D is dramatically slowed, resulting in a prolonged half-life and long-lasting elevations of plasma and tissue levels after exogenous administration [18]. Loss of peripheral catabolism therefore accounts for the increase in plasma levels of 1,25(OH)₂D [and occasionally 25(OH)D itself] in patients with CYP24A1 inactivating mutations.

Observations in our patients (in particular Patient 1) are novel for several aspects, and allow relevant clinical and pathophysiological insight. A first remark is that 1,25(OH)₂D production is not completely inhibited in these patients, despite concurrent hypercalcaemia, high 1,25(OH)₂D levels and suppressed PTH, known inhibitors of CYP27B1 [19]. In fact, 1,25(OH)₂D levels fell after ketoconazole treatment (a vitamin D-1 α -hydroxylase inhibitor) in our and reported patients [8, 13, 16]. Thus, it appears that physiology relies on CYP24A1 to defend against rising plasma calcium above currently accepted 'normal' levels, just like it relies on CYP27B1 to defend against lowering calcium levels.

A second relevant point is the lack of response of hypercalcaemia to CS in CYP24A1 mutations: both our patients, as other reported cases [8], failed to decrease their plasma calcium levels after CS administration, at variance with patients with sarcoidosis (Figure 2) and other calcitriol excess states [20]. CS mechanisms to reduce calcitriol-dependent hypercalcaemia may include reduction of 1,25(OH)₂D production by activated macrophagic/lymphocytic cells [21] and inhibition of intestinal calcium absorption [22, 23]; most notably, CS are potent enhancers of 1,25(OH)₂D-dependent induction of 24(OH)ase expression/activity [19, 22]. Failure of CS to abate plasma calcium levels in CYP24A1 mutation indirectly indicates that intestinal effect is not a major mechanism, while degradation of 1,25(OH)₂D through 24(OH)ase is. In operational terms, CS-resistance in patients with high 1,25(OH)₂D should prompt the search for CYP24A1 mutation as a cause.

While homozygosity/compound heterozygosity in all reported patients with CYP24A1 mutations suggests recessive inheritance, autosomal dominant transmission with incomplete penetrance has been suggested [16]. In our patients'

family, nephrolithiasis occurred in fathers of both patients (one carrier and one not tested); in six relatives, plasma calcium and PTH were normal in all, but $1,25(\text{OH})_2\text{D}$ levels were definitely high in two of four and high-normal in the other two, with hypercalciuria in two of six. Thus, heterozygous carriers may also have subtle abnormalities of vitamin D metabolism, predisposing to clinical events such as renal stones. As already suggested [13], genotyping for CYP24A1 in larger cohorts of patients possibly at risk (e.g. idiopathic calcium nephrolithiasis) might prove informative.

One unusual feature in Patient 1 is the eventual increase of PTH levels, from frankly depressed (and appropriate for the hypercalcaemia) to 'normal' values (yet inappropriate for the unchanged degree of hypercalcaemia). This PTH pattern has relevant diagnostic implications (we would have hardly searched for CYP24A1 mutations with recent picture, if historical data were not well known to us). PTH increase was inversely related to the progressive decline of GFR, apparently in a similar manner as predicted by the known relationship between PTH and fall in GFR in chronic renal diseases [24], though with an apparent leftward shift of this relationship (Figure 4). Sensing mechanism for this PTH increase was not plasma calcium (which remained increased), but $1,25(\text{OH})_2\text{D}$ levels, which decreased with GFR fall and were inversely correlated with PTH changes (Figure 4). A relationship between GFR (i.e. renal mass) and $1,25(\text{OH})_2\text{D}$ levels is consistent with previous reports [25], and allows to explain the progressive fall with time of $1,25(\text{OH})_2\text{D}$ in Patient 1, though to substantially higher than expected levels for any degree of GFR (Figure 4). Data in our patient confirm that calcium and calcitriol independently affect parathyroid function in uraemia, and that $1,25(\text{OH})_2\text{D}$ sensing by the parathyroids may even prevail over Ca sensing, with unexpected and still undescribed results.

Another point deserving interpretation is persistent hypercalcaemia in Patient 1, despite reduction of $1,25(\text{OH})_2\text{D}$ to normal. In contrast, Patient 2, with frankly increased $1,25(\text{OH})_2\text{D}$ levels, had mild hypercalcaemia with severe hypercalciuria. This latter scenario usually occurs in calcitriol excess states as long as renal function is not impaired and characterized other, though not all, reported patients with CYP24A1 mutations [13, 16]. Normal $1,25(\text{OH})_2\text{D}$ levels have also been reported in hypercalcaemic patients with CYP24A1 mutations [11, 12], and were assumed to represent increased $1,25(\text{OH})_2\text{D}$ effect at tissue level irrespective of plasma values. Renal function was not reported in those patients. We analysed the interplay of renal function and plasma $1,25(\text{OH})_2\text{D}$, in relation to urine and plasma calcium levels in our patients. Urine calcium excretion fell in parallel with GFR changes; determinants of this reduction were mainly the decrease of filtered load (due to fall in GFR, since plasma calcium remained high), and possibly an inability of the already maximally stimulated (by hypercalcaemia) CaR-related tubular mechanisms to increase calcium excretion. In addition, the increase in time of PTH was likely to impair maximal kidney capacity to excrete calcium. As a result of all these mechanisms, balance between calcium load into extracellular fluids and urine excretion (the main determinant of plasma calcium levels in vitamin D-dependent hypercalcaemia) [1] was likely to remain

unchanged throughout different ranges of GFR and $1,25(\text{OH})_2\text{D}$ levels, accounting for persistence of hypercalcaemia despite presumably lower calcium load to extracellular fluids.

Indirect support to this interpretation is the observation that hypercalcaemia in infants with CYP24A1 mutations is most severe in the first days/months of life [11] (when renal function in relation to body mass is low) [26] and decreases after several years of follow-up, when presumably the GFR to body mass improves. An intuitive appreciation of the contemporary effects of GFR, calcium load [i.e. $1,25(\text{OH})_2\text{D}$ levels] and urine excretion is offered by the direct correlation between plasma calcium and the ratio of $1,25(\text{OH})_2\text{D}$ to GFR through the whole physiological to pathological ranges (Figure 5).

While it is intuitive that, in steady state, balance between load and renal function/mass is a determinant of plasma calcium levels, it is amazing that nature achieved tight control of that balance by locating into the kidney itself the production of the main determinant of external calcium load, i.e. $1,25(\text{OH})_2\text{D}$. In this view, progressive reduction of $1,25(\text{OH})_2\text{D}$ production with loss of kidney function appears a protective event, rather than a 'maladaptive response' as usually claimed. This is a new concept, a possible background for the interpretation of the severe vascular calcifications associated with vitamin D administration in renal failure [27–29] and in our two patients, and which might lead to revise current practices of VDR agonist usage in renal failure.

Patients with CYP24A1 mutation have unexpectedly low or low-normal phosphate levels despite depressed PTH levels [16, 17]. Both our patients had increased FGF23: Patient 1 (with stage 3b renal insufficiency) with both the Immunotopics C-terminal and the Kaynos intact assays, while Patient 2 only with the Kaynos assay; this latter assay proved the most sensitive in detecting increased FGF23 in patients with tumour-induced osteomalacia [10]. In other two reported patients, FGF23 was normal in one [13] and increased in another [17], both with the C-terminal assay. $1,25(\text{OH})_2\text{D}$ is both a physiologic stimulator to FGF23 synthesis and target of FGF23 through CYP24A1 induction [30]; thus, in presence of CYP24A1 loss of function, calcitriol stimulation on FGF23 secretion remains unabated. Any role, if any, of renal failure in Patient 1 remains speculative, as mechanistic cause for FGF23 rise with falling GFR is lacking. CYP24A1 inactivating mutations may represent another natural model of chronic elevations of FGF23.

Both our patients had increased or high-normal BMD; others have reported normal [15, 17] or reduced [13, 16] values. Reduced production of $24, 25(\text{OH})_2\text{D}$ due to CYP24A1 mutations was suggested as a possible cause of low bone formation and bone fragility [16]. We did not measure $24, 25(\text{OH})_2\text{D}$ levels, yet they are expected to be very low to undetectable, as shown in patients with the same two mutations of our patients [8, 11–13] and with CYP24A1 mutations in general [11, 13, 16]. Thus, other and still unexplored factors than enzyme mutation and hormonal profile are likely to account for variable bone status in these patients.

Though our study has limitations, i.e. the small patient number and the observational clinical context, it has strength, namely the long time of observation for Patient 1 and a very

rich and careful documentation of mineral metabolic profile at each time.

In conclusion, inactivating mutations of CYP24A1 have to be considered as a cause of chronic non-parathyroid hypercalcaemia not only in infants but also in adults. Glucocorticoid-resistance differentiates this entity from other calcitriol-dependent hypercalcaemic disorders. Typical biochemical profile (hypercalcaemia/hypercalciuria with depressed PTH) may be masked by concomitant renal failure. Investigation of the underlying pathophysiology of this disorder suggests that reciprocal interdependence between 1,25(OH)₂D production and renal mass is a means for the control of appropriate calcium balance and calcium levels in body fluids along different degrees of renal function, which should be taken into account when treating patients with chronic renal disease.

ACKNOWLEDGEMENTS

We warmly thank Dr Piergiorgio Messa for performing FGF23 measurements in his laboratory.

CONFLICT OF INTEREST STATEMENT

None declared.

REFERENCES

1. Bilezikian JP. Hypercalcemia states. In: Coe FL, Favus MJ (eds). Disorders of Bone and Mineral Metabolism. New York: Raven Press, 1992, pp. 493–522
2. Shane S. Clinical manifestations of hypercalcemia. In: Basow DS (eds). UpToDate. Wolters Kluwer, Waltham, MA, 2013
3. Coe FL, Favus M. Does mild, asymptomatic hyperparathyroidism require surgery? *New Eng J Med* 1980; 302: 224–225
4. Marone C, Beretta-Piccoli C, Weidmann P. Acute hypercalcemic hypertension in man: role of hemodynamics, catecholamines, and renin. *Kidney Int* 1981; 20: 92–96
5. Walker MD, Silverberg SJ. Cardiovascular aspects of primary hyperparathyroidism. *J Endocrinol Invest* 2008; 31: 925–931
6. Palmer M, Adami HO, Bergstrom R *et al*. Survival and renal function in untreated hypercalcemia. Population-based cohort study with 14 years of follow-up. *Lancet* 1987; 329: 59–62
7. Palmer M, Adami HO, Bergstrom R *et al*. Mortality after surgery for primary hyperparathyroidism: a follow-up of 441 patients operated on from 1956 to 1979. *Surgery* 1987; 102: 1–7
8. Dinour D, Beckerman P, Ganon L *et al*. Loss-of-function mutations of CYP24A1, the vitamin D 24-hydroxylase gene, cause long-standing hypercalcemic nephrolithiasis and nephrocalcinosis. *J Urol* 2013; 190: 552–557
9. Colussi G, Macaluso M, Brunati C *et al*. Calcium metabolism and calciotropic hormone levels in Gitelman's syndrome. *Min Electrolyte Metab* 1994; 20: 294–301
10. Imel EA, Peacock M, Pitukcheewanont P *et al*. Sensitivity of fibroblast growth factor 23 measurement in tumor-induced osteomalacia. *J Clin Endocrinol Metab* 2006; 91: 2055–2061

11. Schlingmann KP, Kaufmann M, Weber S *et al*. Mutations in CYP24A1 and Idiopathic Infantile Hypercalcemia. *N Engl J Med* 2011; 365: 410–421
12. Dauber A, Nguyen TT, Sochett E *et al*. Genetic defect in CYP24A1, the vitamin D 24-hydroxylase gene, in a patient with severe infantile hypercalcemia. *J Clin Endocrinol Metab* 2012; 97: E268–E274
13. Nesterova G, Malicdan MC, Yasuda K *et al*. 1,25-(OH)₂D-24 Hydroxylase (CYP24A1) Deficiency as a Cause of Nephrolithiasis. *Clin J Am Soc Nephrol* 2013; 8: 649–657
14. Fencel F, Blahova K, Schlingmann KP *et al*. Severe hypercalcemic crisis in an infant with idiopathic infantile hypercalcemia caused by mutation in CYP24A1 gene. *Eur J Pediatr* 2013; 172: 45–49
15. Streaten EA, Zarbalian K, Damcott CM. CYP24A1 mutations in idiopathic infantile hypercalcemia. *N Engl J Med* 2011; 365: 1741–1742
16. Tebben PJ, Milliner DS, Horst RL *et al*. Hypercalcemia, hypercalciuria, and elevated calcitriol concentrations with autosomal dominant transmission due to CYP24A1 mutations: effects of ketoconazole therapy. *J Clin Endocrinol Metab* 2012; 97: E423–E427
17. Meusburger E, Mündlein A, Zitt E *et al*. Medullary nephrocalcinosis in an adult patient with idiopathic infantile hypercalcemia and a novel CYP24A1 mutation. *Clin Kidney J* 2013; 6: 211–215
18. Masuda S, Byford V, Arabian A *et al*. Altered pharmacokinetics of 1 α ,25-dihydroxyvitamin D₃ and 25-hydroxyvitamin D₃ in the blood and tissues of the 25-hydroxyvitamin D-24-hydroxylase (*Cyp24a1*) null mouse. *Endocrinology* 2005; 146: 825–834
19. Jones G, Prosser DE, Kaufmann M. 25-Hydroxyvitamin D-24-hydroxylase (CYP24A1): its important role in the degradation of vitamin D. *Arch Biochem Biophys* 2012; 523: 9–19
20. Kerr DNS. Hypercalcemia and metastatic calcification. *Cardiovasc Res* 1997; 36: 293–297
21. Sandler LM, Winearls CG, Fraher LJ *et al*. Studies of the hypercalcaemia of sarcoidosis: effect of steroids and exogenous vitamin D₃ on the circulating concentrations of 1,25-dihydroxy vitamin D₃. *Q J Med* 1984; 53: 165–180
22. Dhawan P, Christakos S. Novel regulation of 25-hydroxyvitamin D₃ 24-hydroxylase (24(OH)ase) transcription by glucocorticoids: cooperative effects of the glucocorticoid receptor, C-EBP β , and the vitamin D receptor in 24(OH)ase transcription. *J Cell Biochem* 2010; 110: 1314–1323
23. Huybers S, Naber TH, Bindels RJ *et al*. Prednisolone-induced Ca²⁺ malabsorption is caused by diminished expression of epithelial Ca²⁺ channel TRPV6. *Am J Physiol Gastrointest Liver Physiol* 2007; 292: G92–G97
24. Levin A, Bakris GL, Molitch M *et al*. Prevalence of abnormal serum Vitamin D, PTH, calcium, and phosphorus in patients with chronic kidney disease: results of the study to evaluate early kidney disease. *Kidney Int* 2007; 71: 31–38
25. Patron P, Chardin JP, Paillard M. Renal mass and reserve of vitamin D: determinants in primary hyperparathyroidism. *Kidney Int* 1987; 31: 1174–1980
26. Quigley R. Developmental changes in renal function. *Curr Opin Pediatr* 2012; 24: 184–190
27. Haffner D, Hocher B, Müller D *et al*. Systemic cardiovascular disease in uremic rats induced by 1,25(OH)₂D₃. *J Hypertens* 2005; 23: 1067–1075
28. Miller PD, Vitamin D. Calcium, and cardiovascular mortality: a perspective from a plenary lecture given at the annual meeting of the American Association of Clinical Endocrinologists. *Endocr Pract* 2011; 17: 798–806
29. Zittermann A, Koerfer R. Protective and toxic effects of vitamin D on vascular calcification: clinical implications. *Mol Aspects Med* 2008; 29: 423–432
30. Liu S, Tang W, Zhou J *et al*. Fibroblast growth factor 23 is a counter-regulatory phosphaturic hormone for vitamin D. *J Am Soc Nephrol* 2006; 17: 1305–1315

Received for publication: 19.8.2013; Accepted in revised form: 25.9.2013